

1

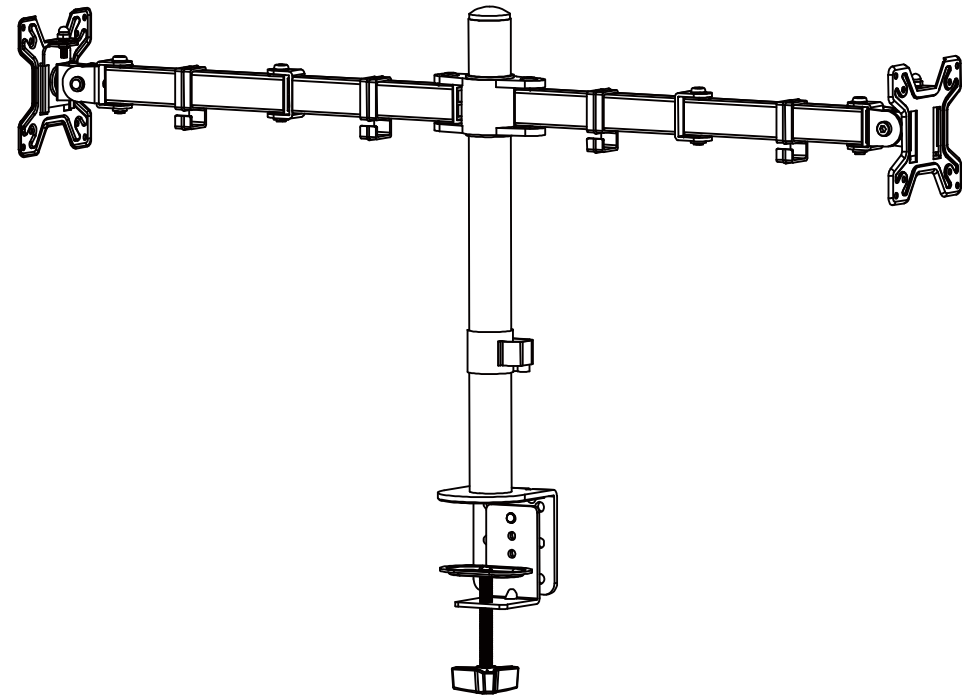

75x75
100x100

27"
MAX











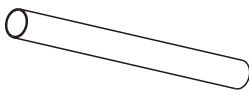



8kg
(18lbs)
MAX

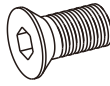

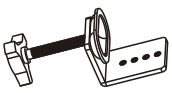
CAUTION: DO NOT EXCEED RATED LISTED WEIGHT. SERIOUS INJURY OR PROPERTY DAMAGE MAY OCCUR! WE DO NOT RESPOSIBLE FOR DAMAGES CASUSED BY IMPROPER INSTALLATION!

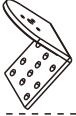
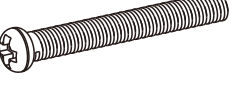
129.189

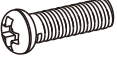
PART LIST

	① X1		M6 A X2		H X8
	② X1		M8x10 B X2		I X1
	③ X2		M5x16 C X3		J X4
	④ X1		M4x8 D X8		K X1
	⑤ X1		M4x30 F X8		L X1
			M4x12 G X8		M X1

2

