CX-1000B
SUBWOOFER CABINET
Order ref: 170.217
User Manual



High energy sub cabinet made from premium Russian ply with custom drive units.

Computer designed bracing and porting of the enclosure help to optimize and focus low frequencies.

Capable of developing high SPL output, this sub unit is a key component for any large sound reinforcement system.

- Durable textured black paint finish
- 16 x M10 flying points
- Heavy duty powder-coated steel grille
- Speakon® connectors fitted
- Top mounted 35mm pole mount socket
- All fittings rebated for easier stacking and arraying
- Steel bar handles fitted as standard

Specifications

Power RMS	1000W
Power Max	1600W (5 minutes max)
LF drivers	2 x 450mmØ (18")
Impedance	4Ω
Frequency response (-3dB)	35Hz – 1.6KHz
Frequency response (-10dB)	30Hz – 2.0KHz
Sensitivity (1W/1m)	100dB
Connectors	2 x Speakon® (NL 4)
Dimensions	575 x 1225 x 572mm
Weight	80kg

Technical drawings

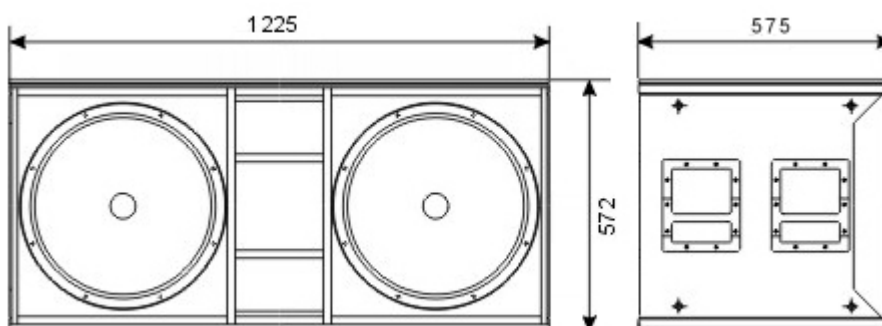

Technical Diagrams

Frequency response - Magnitude

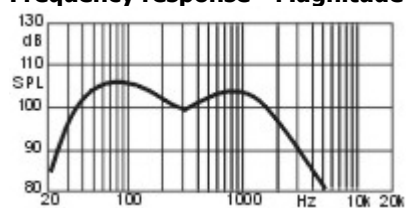

Impedance - Magnitude

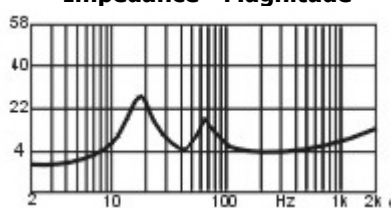

Distortion - Magnitude

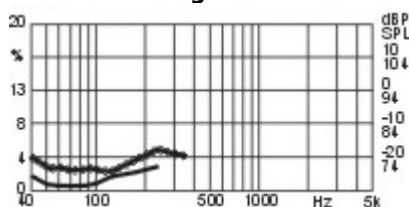

Combination - Magnitude

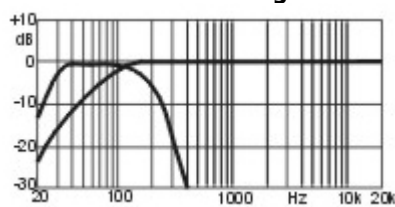

Connection

