

# USER MANUAL

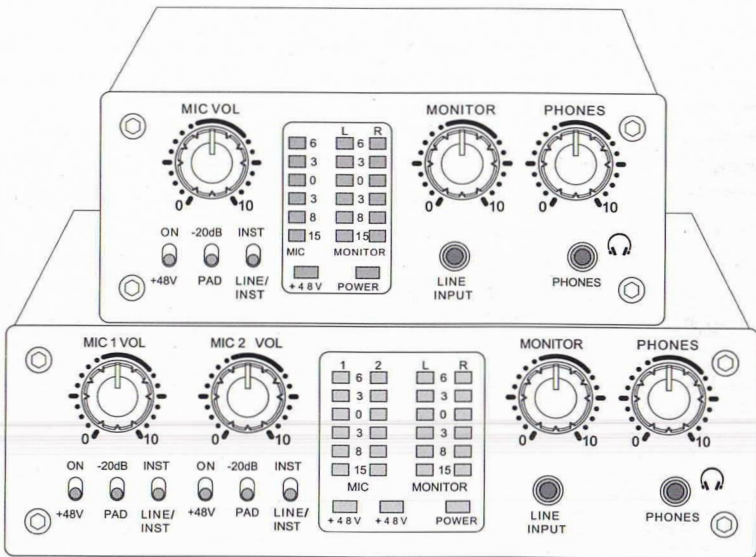

We greatly appreciate your purchase of this mike/guitar pre-amp with a USB2.0 audio port. This style has its excellence in performance, and it is firm, enduring and reliable. It brings great fun and convenience to your work, life and leisure hours for you between music and your computer.

We would sincerely offer our after-sales services that you need for this product. Before use, carefully read this user manual and keep it for your random reference. Thanks again for your patronage.

These compact, firm and portable small boxes are fun and practical. They can be connected to many kinds of audio appliances, and they are used in a wide range of applications. The style brings up much fun and easy use to your work, life, leisure and etc., for you between music and your computer.

What you need is only a USB cord to connect it to your computer. It can record fast your sound or your singing sound, or the sound you want to record. And you can share and transmit them real-time through the internet. The portable design can also mark down your creational inspiration any time anywhere. It is one of the necessities which is always handy for music lovers, creators, singers and network broadcasters. Just plug in to use. It is needless to install a 24bit sound card with a special driving program. It is comparable with the Windows XP+ and OS X systems, and also comparable with the audio editing and making softwares supporting the Core Audio or WDM standard, the music player and the professional audio analyzing and testing softwares, and the ones of interactive social programs, network Karaoke and chatting on the internet. It can record and replay at the same time to do a dual work.

The specially designed A-type microphone pre-amplifier has extremely low noise, distortion and a very high dynamic range, built in with 48V phantom power, which can be connected with a condenser microphone. The product has an input resistance shifting switch to match high-impedance input equipment such as an electric guitar. This mike/guitar preamplifier can provide an original, true and warm sound reappearance.

1, To set up your personal professional recording studio.

Your sound can be recorded through these USB sound cards on your MAC or Windows computers. Plugging in microphones, music instruments or sound sources, you may record your creational inspiration, or the sound that you want to record, through the connections between these USB sound cards and your computer in combination of your record software. By combining the software and hardware, you will find that you can easily take the professional audio studio with you at any time. The fun of this is great. The USB sound cards can be comparable with many audio editing and making softwares that support Core Audio or WDM standard.

2, On the internet, you can use these USB sound cards to play on-the-net Karaoke singing, interact real-time lively with friends, play net live shows or performances, or publicize and share your works. The USB sound cards have the lowest transmitting delay property, and has great comparability with many social interactive softwares on the internet. They can transmit out your sound wholly in a fast speed, pulling close the distance between you and your friends or fans. The fast-speed USB sound cards will record your audio equipment such as microphones, guitars, keyboards, etc. In the meantime, it will guarantee the purity of sound and a wide frequency range.

The 24bit transformer in a studio-room grade will restore the quality of the sound to the greatest extent. No matter you are a singer, a radio host, or a YY anchor, or you only do recording or playing of instruments at home, they can satisfy your requirements in the field of digital audio.

### 3, High-quality digital music player.

When you use the computer to play music, watch movies, play games, see the internet videos, you will also want better audio effects and listening feelings. The sound-replaying performance of these USB sound cards, as compared with the sound cards equipped by the original computers, have a better signal-to-noise ratio, a wider frequency response and a higher dynamic range. Meanwhile, it has a more convenient control and output monitoring method. The 24bit DAC and high-quality mixing line in high sampling precision offers you a more good-listening, and more impacting audio effect.

### 4, To perform the tests and analysis of acoustic parameters in the sound space.

Connecting the USB sound cards to your computer, plugging in a microphone in conformity with the testing standard, combining the testing and analyzing software of audio spectrum in your computer, you can fast perform the acoustic testing of the sound space to analyze, and help you effectively correct the acoustic parameters in the space, raising the sound replay effects of the space.

### **The warranty period of one year.**

This product is guaranteed for no material or workmanship defects within one year's period from the purchase date of the original buyer. To ensure the high-level performance of the property and reliability in the design and manufacture of this appliance, please read the user's manual before operation.

In case of malfunction, please inform immediately and return the machine with defects to us, or our authorized agent, and go repairing according to the following conditions within the warranty period:

#### **Warranty conditions**

The device must be installed and operated according to the instructions of this manual.

The device hasn't gone through any intentional or unintentional mistaken uses, neglects or alterations which are described in this manual, or authorized by us. Any necessary adjustment, correction or repairing should be carried out by us or any authorized agent of this device.

Please attach the purchase proof with freight prepaid when you return the defective machine to us or our authorized agent. The machine returned should be packed well and avoid\*possible damages on the way of transit.

In some area, these stipulations may vary. Concerning with any possibly adoptive additional warranty clauses, please contact our sales agent.

## **NOTICE**

To avoid the possibility of malfunction/ damage to the product, damage to data, or damage to other property, follow the notices below.

### **Handling and maintenance**

- Do not use the device in the vicinity of a TV, radio, stereo equipment, mobile phone, or other electric devices. Otherwise, the device, TV, or radio may generate noise.
- Do not expose the device to excessive dust or vibration, or extreme cold or heat (such as in direct sunlight, near a heater, or in a car during the day), in order to prevent the possibility of panel disfiguration, unstable operation, or damage to the internal components.
- Do not place vinyl, plastic or rubber objects on the device, since this might discolor the panel.
- When cleaning the device, use a dry and soft cloth. Do not use paint thinners, solvents, cleaning fluids, or chemical impregnated wiping cloths.
- Condensation can occur in the device due to rapid, drastic changes in ambient temperature-when the device is moved from one location to another, or air conditioning is turned on or off, for example. Using the device while condensation is present can cause damage. If there is reason to believe that condensation might have occurred, leave the device for several hours without turning on the power until the condensation has completely dried out.
- Avoid setting all equalizer controls and faders to their maximum. Depending on the condition of the connected devices, doing so may cause feedback and may damage the speakers.
- Do not apply oil, grease, or contact cleaner to the faders. Doing so may cause problems with electrical contact or knob motion.
- When turning on the AC power in your audio system, always turn on the power amplifier LAST, to avoid speaker damage. When turning the power off, the power amplifier should be turned off FIRST for the same reason.

### **Notice for the use of the USB2.0 and the audio property setup of the computer:**

When connecting the computer to the USB 2.0 connector, make sure to observe the following points. Failing to do so risks freezing the computer and corrupting or losing the data. If the computer or the mixer freezes, restart the application software or the computer OS, or don't connect the mixer and then on again.

- Use an AB type USB cable. USB 3.0 cable cannot be used.
- Before connecting the computer to the USB 2.0 terminal, exit from any power-saving mode of the computer (such as suspend, sleep, standby).
- There is no need to install any specialized driving program for this USB2.0 audio port. Just plug in to use. For the first use, the computer will find a new hardware. Please follow the operations to complete all installations as instructed by the computer until the recognition of ending by the computer. Then, the USB2.0 external sound card is ready to use.
- The USB2.0 external sound card is named as USB AUDIO 24BIT. It is comparable with Windows XP+ and MAC OS X operation systems. After recognition of the external sound card by the computer, you choose as the current audio input and output device in the audio device properties. If it cannot be set up automatically, you are required to enter the computer's audio device properties, and then choose the "USB AUDIO 24BIT" in the drawdown list of the input and output audio device.
- To secure better sound effects, we recommend you to set up the input and output volume to the maximum in the audio properties of the computer system.

# Schematic diagram of equipment connection

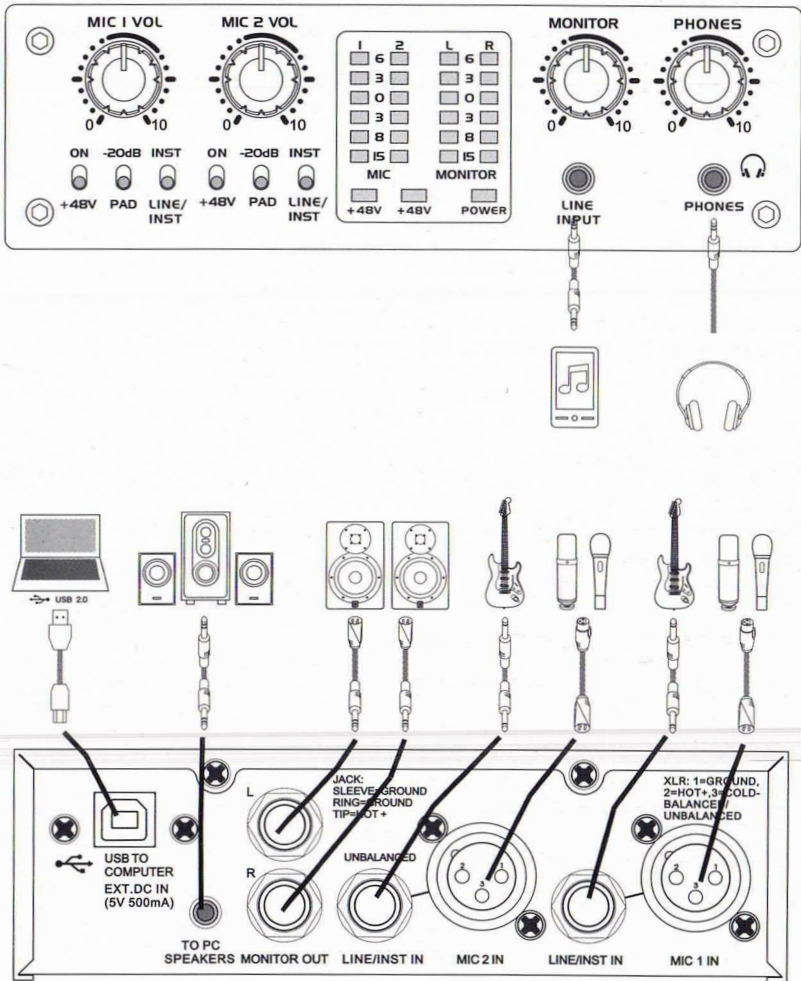

## Front panel function

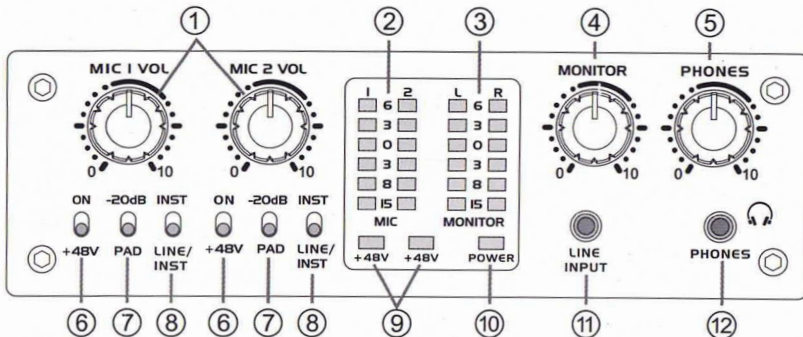

### 1, MIC input 1&2 volume knob:

Adjust the volume of the sound input from the microphone or other source connected to channel .

### 2, MIC input channel 1&2 volume level meter:

When the peak light flashes, indicating that the input signal is too high, please turn the volume knob to the left to reduce the volume. In normal use, please avoid the peak light for a long time;

### 3, Monitor the main output of the volume level meter;

### 4, The MONITOR output volume knob;

### 5, The PHONES output volume knob;

### 6, +48V phantom switch

When this switch is turned on , the +48V LED lights and DC +48 V phantom power is supplied to the XLR plug on MIC input jack .

#### NOTICE

Be sure to leave this switch off if you do not need phantom power. Follow the important precautions below, in order to prevent noise and possible damage to external devices as well as the mixer if you turn this switch on .Be sure to leave this switch off when you connect a device that does not support phantom power to channel . Make sure to turn this switch off when connecting/disconnecting a cable to/from channel . Slide the knob on channel to minimum before turning this switch on /off .

### 7, PAD switch

When you need to connect to a high level input signal source, turn this switch on.

NOTE: Slide the fader to minimum before toggling the PAD switch on and off . Otherwise, noise may be produced.

### 8, Guitar/Line input shifter

The switch is used to shift the connections to different sound sources of the input channels. Switched up, the input channel can be connected directly with a high-impedance audio device such as an electric guitar or a bass. Switched down, it can be connected to a low-impedance sound device. Warning!

In operation of the switch, all level output control (such as channel volume knobs, monitor output knobs and earphone knobs) should be set up to the minimum position. Because this operation will cause a sudden impact sound, which can damage the external devices, and the hearing of the personnel on site.

### 9, 48V phantom power LED:

When the lamp is lit, said 48V phantom power is provided to XLR MIC input channel;

### 10, Power LED:

### 11, 3.5mm-spec stereo line input jack:

The jack has no independent volume control knob. When you need to use, please connect music play devices with a volume control, and use the volume setting of the device to set the input level of this device.

### 12, 3.5mm-spec stereo PHONES output jack:

## Rear panel function

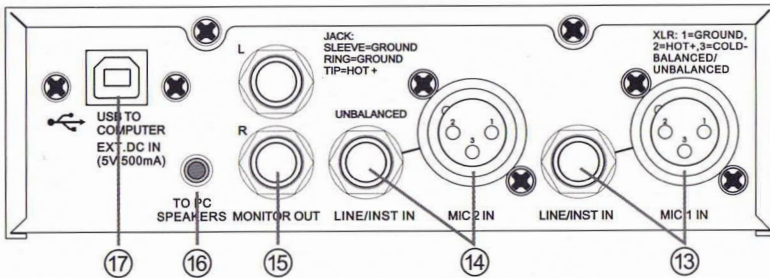

### 13, Mike/Line/Guitar input jacks of MIC 1 channel

The jacks are used to connect microphones or other audio devices in support of cannon plugs and 6.35 plugs. These two jacks are paralleled and are input to the MIC 1 input channel together. We do not recommend the use of these two jacks at one time, i.e. you can only use one of them at one time. Because with two devices being plugged in, it will cause unnecessary interference, affecting the music effects.

### 14, Mike/Line/Guitar input jacks of MIC 2 channel

Function is exactly the same as MIC 1, see.

### 15, MONITOR output jacks:

Support 6.35mm specifications for the connection of active speakers, power amplifiers or other audio devices.

### 16, 3.5mm monitoring output jack

The jack is in support of 3.5mm specifications, especially for the use of the active loudspeakers of the computer. You can of course use it to connect power amplifiers or other audio equipment. The output volume is controlled by the volume monitoring knobs on the panel.

### 17, USB 2.0 terminal

For connecting to a computer using the included USB 2.0 cable. When connected to a computer, the computer supplies power to the mixer and audio data can be sent between the mixer and computer.

#### NOTICE!

Please do not connect any device to USB 2.0 terminal other than personal computers or tablet devices.

#### NOTICE!

Please read the safety precautions for the USB power adapter or USB mobile battery that you are using. Use a USB power adapter or USB mobile battery that can supply power via a USB micro B plug based on the following USB standards:

Output voltage: 4.8 V to 5.2 V

Output current: 0.5 A or greater

## General Specifications

### Input Channels

Mono (MIC/LINE): 2 ;

Stereo (LINE): 1 ;

USB PLAYBACK: 1 ;

### Output Channels

MAIN L/R OUT: 1 ;

PHONES: 1 ;

Stereo: 1

### Bus

### Input Channel Function CH1/2 MIC/LINE

**GAIN**, -14~+40 dB;

**PAD**, 20 dB;

**+48V**, Phantom Power, LED;

**IMPEDANCE** Switch;

6 point LED meter;

Stereo Input / Stereo Output;

USB Audio Class 2.0 compliant;

Sampling Frequency: Max 96 KHz, Bit Depth: 24-bit;

Type B connector;

2x6 point LED meter ;

3 Vrms;

$\pm 0.5$  dB, 20-20000Hz;

102 dB;

$\leq 0.03\%$ ;

92 dB;

DC 5 V, 500 mA

### Level Meter

### Max output level

### Frequency response

### Dynamic range

### THD+N @ 1KHz

### Stereo crosstalk

### Power Requirements

### Power Consumption

### Dimensions (WxHxD)

### Net Weight

Max. 2.5 W

160 mm x 50 mm x 92 mm

0.64 kg

## BLOCK DIAGRAM

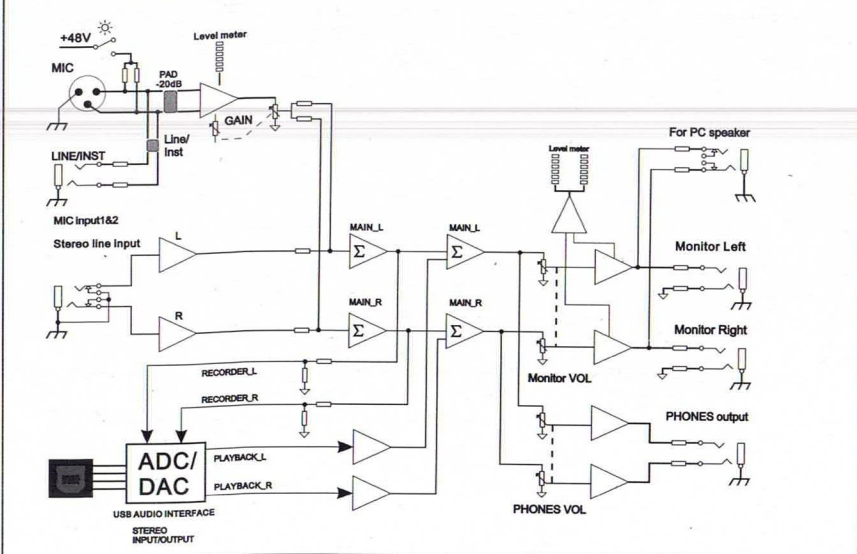



# Schematic diagram of equipment connection

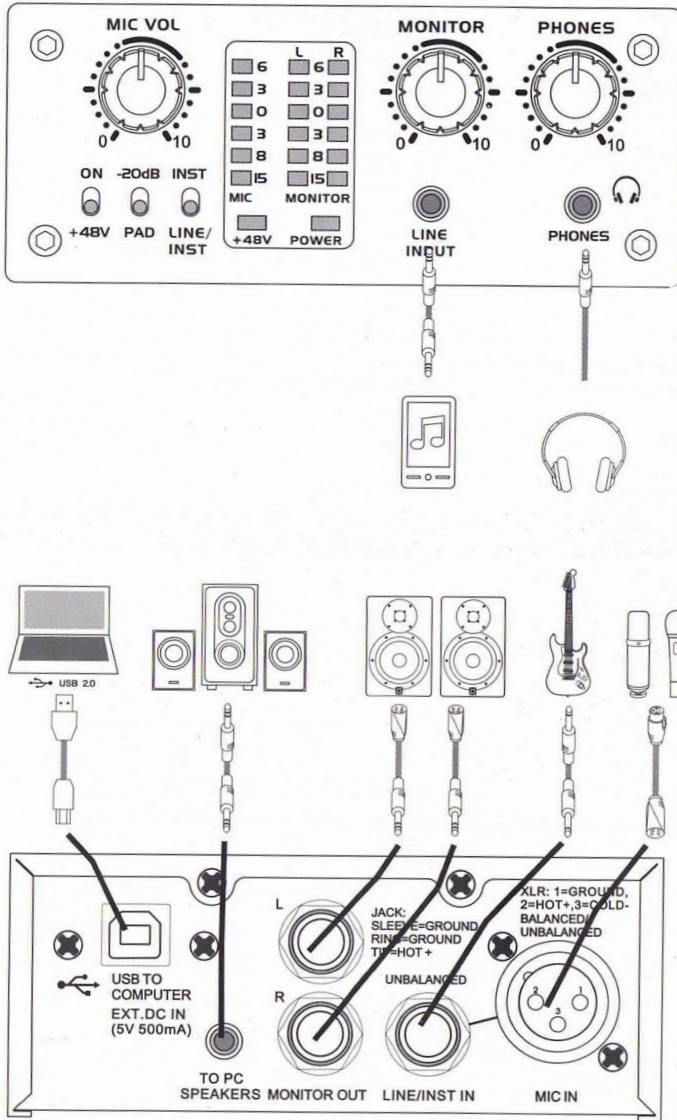

## Front panel function

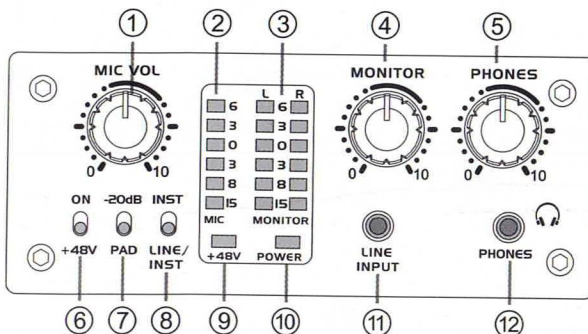

### 1, MIC input 1 volume knob:

Adjust the volume of the sound input from the microphone or other source connected to channel .

### 2, MIC input channel 1 volume level meter:

When the peak light flashes, indicating that the input signal is too high, please turn the volume knob to the left to reduce the volume. In normal use, please avoid the peak light for a long time;

### 3, Monitor the main output of the volume level meter;

### 4, The MONITOR output volume knob;

### 5, The PHONES output volume knob;

### 6, +48V phantom switch

When this switch is turned on, the +48V LED lights and DC +48 V phantom power is supplied to the XLR plug on MIC input jack .

### NOTICE

Be sure to leave this switch off if you do not need phantom power. Follow the important precautions below, in order to prevent noise and possible damage to external devices as well as the mixer if you turn this switch on .Be sure to leave this switch off when you connect a device that does not support phantom power to channel . Make sure to turn this switch off when connecting/disconnecting a cable to/from channel . Slide the knob on channel to minimum before turning this switch on /off .

### 7, PAD switch

When you need to connect to a high level input signal source, turn this switch on.

NOTE: Slide the fader to minimum before toggling the PAD switch on and off . Otherwise, noise may be produced.

### 8, Guitar/Line input shifter

The switch is used to shift the connections to different sound sources of the input channels. Switched up, the input channel can be connected directly with a high-impedance audio device such an electric guitar or a bass. Switched down, it can be connected to a low-impedance sound device.

### Warning!

In operation of the switch, all level output control (such as channel volumn knobs, monitor output knobs and earphone knobs) should be set up to the minimun position. Because this operation will cause a sudden impact sound, which can damage the external devices, and the hearing of the personnel on site.

### 9, 48V phantom power LED:

When the lamp is lit, said 48V phantom power is provided to XLR MIC input channel;

### 10, Power LED:

### 11, 3.5mm-spec stereo line input jack:

The jack has no independent volumn control knob. When you need to use, please connect music play devices with a volumn cotrol, and use the volumn setting of the device to set the input level of this device.

### 12, 3.5mm-spec stereo PHONES output jack:

## Rear panel function

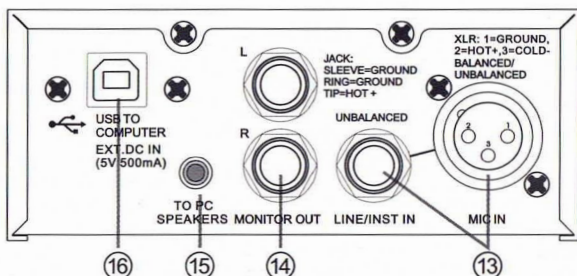

### 13, Mike/Line/Guitar input jacks of MIC 1 channel

The jacks are used to connect microphones or other audio devices in support of cannon plugs and 6.35 plugs. These two jacks are paralleled and are input to the MIC 1 input channel together. We do not recommend the use of these two jacks at one time, i.e. you can only use one of them at one time. Because with two devices being plugged in, it will cause unnecessary interference, affecting the music effects.

### 14, MONITOR output jacks:

Support 6.35mm specifications for the connection of active speakers, power amplifiers or other audio devices.

### 15, 3.5mm monitoring output jack

The jack is in support of 3.5mm specifications, especially for the use of the active loudspeakers of the computer. You can of course use it to connect power amplifiers or other audio equipment. The output volume is controlled by the volume monitoring knobs on the panel.

### 16, USB 2.0 terminal

For connecting to a computer using the included USB 2.0 cable. When connected to a computer, the computer supplies power to the mixer and audio data can be sent between the mixer and computer.

#### NOTICE!

Please do not connect any device to USB 2.0 terminal other than personal computers or tablet devices.

#### NOTICE!

Please read the safety precautions for the USB power adapter or USB mobile battery that you are using. Use a USB power adapter or USB mobile battery that can supply power via a USB micro B plug based on the following USB standards:

Output voltage: 4.8 V to 5.2 V

Output current: 0.5 A or greater

## General Specifications

### Input Channels

Mono (MIC/LINE): 1 ;  
Stereo (LINE): 1 ;  
USB PLAYBACK: 1 ;

### Output Channels

MAIN L/R OUT: 1 ;  
PHONES: 1 ;  
Stereo: 1

### Bus

### Input Channel Function CH1/2 MIC/LINE

**GAIN**, -14~+40 dB;  
**PAD**, 20 dB;  
**+48V**, Phantom Power, LED;  
**IMPEDANCE** Switch;  
6 point LED meter;

### USB Audio

Stereo Input / Stereo Output;  
USB Audio Class 2.0 compliant;  
Sampling Frequency: Max 96 KHz, Bit Depth: 24-bit;  
Type B connector;

### Level Meter

### Max output level

2x6 point LED meter ;

### Frequency response

3 Vrms;

### Dynamic range

$\pm 0.5$  dB, 20-20000Hz;

### THD+N @ 1KHz

102 dB;

### Stereo crosstalk

$\leq 0.03\%$ ;

### Power Requirements

92 dB;

### Power Consumption

DC 5 V, 500 mA

### Dimensions (WxHxD)

Max. 2.5 W

### Net Weight

120 mm x 50 mm x 92 mm

0.5 kg

## BLOCK DIAGRAM

